

Vertical rail and fall arrester

1. General

When the ladder is more than 8 m high, it must be equipped with a vertical safety rail or ladder cages.

2. Product figures and parts

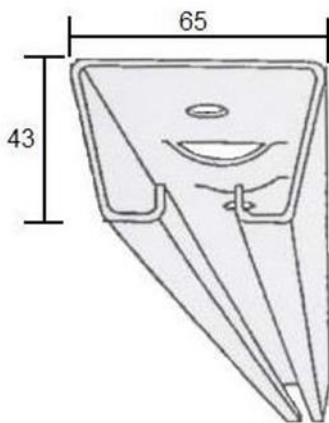

1. Vertical rail



2. Fall arrester and energy absorber

The length of the vertical rail is 3 m (2969 mm), and it can be shortened or extended as necessary. NOTE! The vertical rail always has anti-slip devices on the base as shown in the figure.

Rail system parts:

- Vertical rail
- End bow (including the installation instructions, instructions for use and 2 signs)
- Rung fixture + screws
- Vertical rail extension + screws
- Vertical rail carriage stoppers
- Fall arrester and flexible energy absorber

3. Installation

The maximum distance between vertical rail fixtures on the ladder is 1.8 m. The rail is attached in the middle of the ladder rungs. A rung fixture, a low-head hexagonal head screw M10 x 50, a M10 nut and a M10 flat.

The standard rung fixture is suitable for round ladder rungs with a diameter of 16–34 mm. Specially dimensioned rung fixtures are needed for other types of steps. If the vertical rail is attached to an existing ladder, it must be checked that the rungs are properly attached to the side rails of the ladder. The rail is installed from top to bottom. An end bow is first installed at a height of approximately 60 cm from the platform. The end bow may curve forward (normal ladder) or to the side (side ladder). The end bow must always be attached with minimum two rung fixtures. Once the end bow has been installed, the installation continues with the installation of the required number of vertical rails. The bottom of the vertical rail should be placed at approximately 0.9 m from the bottom of the ladder. Check the straightness of the rail line with an alignment wire, for example. If necessary, unintended exit of the carriage at the rail ends can be stopped using carriage stopper on the vertical rail. **NOTE! The vertical rail may not be installed so that it tilts backwards.**

The vertical rail can be extended with extension parts. Place the extension at the connection of the rails. Attach it with three low-head hexagonal head screws M10 x 25, M10 nuts and a M10 flat. The rail is attached on the ladder rungs on both sides of the connection. A ladder fitted with a vertical rail is marked with a visibly placed sign with instructions to use a fall arrester and a full-body harness always when using the ladder. An additional sign tells where the safety equipment is stored.

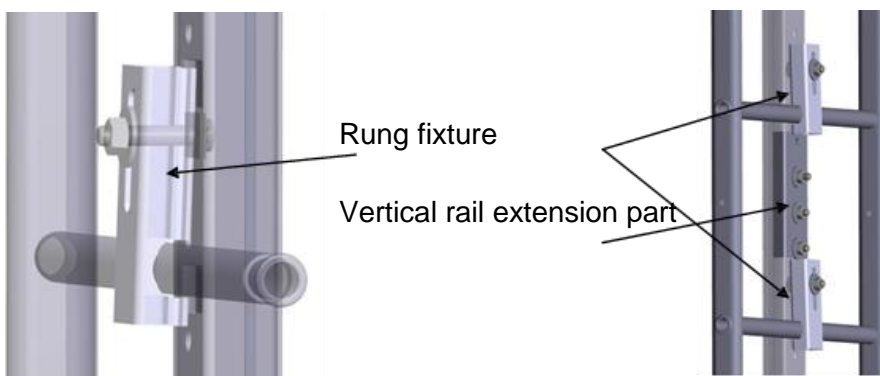
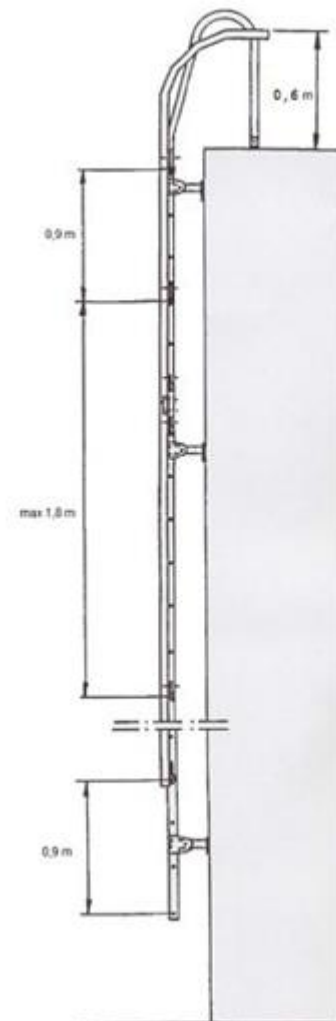

Finally, perform a final inspection:

- The ladder on which the rail is fixed must be attached to the wall reliably.
- The fall arrester must run the entire distance without obstacles, including at connections.
- Whether the fall arrester gets stuck on the anti-slip devices at the base of the rail must be checked by, for example, tugging the fall arrester's energy absorber down when the fall arrester is in the rail.

4. Operation

The user must read the instructions for use before using the rail system. The user must be familiar with the use of fall protection equipment. If there is anything about the user's health that could impact the safety of climbing, the user must check their health and ability to climb with a doctor before climbing.

The vertical rail system and the fall arrester + energy absorber are designed as fall prevention equipment. They are designed for use and tested in the composition described in these installation instructions. Using the rail system for other kinds of fall prevention according to the manufacturer's instructions or making changes to the rail system or the fall arrester + energy absorber is absolutely prohibited without the manufacturer's permission.

Replacing parts of the rail system with parts not approved by the manufacturer of the system is absolutely prohibited. The rail system is not designed for staying in place during working, instead, a separate system must be used for this.

The minimum and maximum weights of the user, including equipment, are 40 kg/120 kg. The minimum and maximum weights indicated in the fall arrester must be observed. The system may be used by one person at a time over a distance of six metres.

The rail system's lowest temperature use is -25°C.

The person climbing the ladder uses a safety harness and a fall arrester with energy absorber to attach to the vertical rail fixed on the rungs of the vertical wall ladder. The vertical rail can also act as the frame of pole rungs. This ensures a safe climb to the roof in all cases. The fall arrester can only be used in Vesivek Tuotteet Oy vertical rails in combination with an CE approved (EN-361) full-body harness.

The arrester attaches to the front attachment point/points of the harness. Both flexible energy absorbers of the fall arrester are attached and secured to the front attachment point/points using their eyebolts. The length of the fall arrester may not be adjusted by removing or adding connectors, for example.

The harness used with the rail system must fit the user, and the adjustments of the harness must be checked before using the system. A loose-fitting harness may not be used. If the harness becomes looser during ascend or descent, it must be readjusted to fit the user before using it again.

The fall arrester is placed on the rail through the rail's open end. The fall arrester is symmetrical; the direction of use is therefore not relevant. The distance between the user and the vertical rail must be approximately 20–25 cm. When climbing up, the user leans slightly backwards, allowing the fall arrester move effortlessly in the profile. The minimum space allowing a safe fall is 2 m under the feet of the user. Special care should therefore be used when climbing up the first 2 metres.

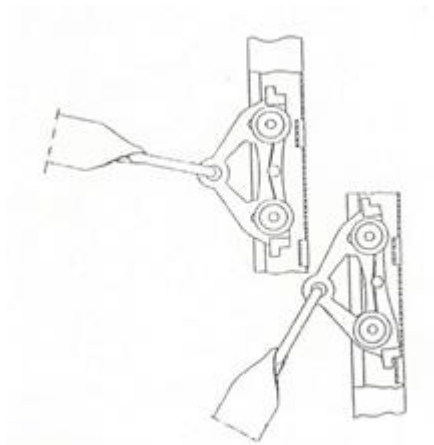

It is **absolutely prohibited** to detach the fall arrester from the harness during climbing and intentionally prevent the fall arrester from locking.

If the user falls from the ladder, the fall arrester locks on an anti-slip device on the rail. In case of a fall, the safety harness and the energy absorber of the fall arrester prevent the user from falling. After a fall, the rail system **may not be used** until the manufacturer or its representative has checked the system. If the energy absorber of the fall arrester has deployed, it must be replaced with a new, intact absorber by the manufacturer or its representative. A deployed energy absorber **may not be used**. The fall arrester of the vertical rail system and the horizontal carriage of the horizontal rail system cannot be interchanged. The horizontal carriage may not be used with the vertical rail system, and the fall arrester may not be used with the horizontal rail.

5. Storage

The fall arrester and the flexible energy absorber must be stored indoors in a dry place. The instructions for use and the inspection card are stored with the fall arrester. The harness is stored according to the manufacturer's instructions.

6. Rescue services

Before using the rail system, the user must familiarise themselves with the rescue instructions and plan how to evacuate in case of accident.

An unconscious or injured person is rescued from a ladder fitted with a vertical rail as follows:

- The rescuer must wear a safety harness and use a fall arrester.
- The rescuer must approach the person being rescued from under and take them on their shoulder.
- When the person being rescued is lifted up, the fall arrester is released, allowing them to be brought down.
- There is no danger of fall since both persons are attached to the vertical rail at all times.

7. Inspections

The system may only be inspected by the manufacturer, a representative of a party authorised by the manufacturer or a party responsible for the safety of the property. The inspection is recorded in the inspection card, detailing the inspection date, inspector, actions/comments, if any, and the next planned inspection date. The inspection card must be stored carefully to enable later monitoring. In case there are any doubts regarding the condition of the vertical rail system or the fall arrester + flexible energy absorber, using them is absolutely prohibited until they have been inspected carefully. If necessary, using the system must be prohibited.

Installation and initial inspection

An initial inspection must be conducted before taking the vertical rail into use. Correct installation and fixing according to the instructions is inspected in this inspection.

Furthermore, the operation of the system must be inspected.

Inspection before each use

The following must be inspected by the user before each use:

- Condition of the springs of the fall arrester: the springs must be in place, and they may not be broken or lost their elasticity.
- The energy absorbers (2/fall arrester) are in order and have not deployed due to a fall. If orange colour and text is visible underneath the cover, the energy absorber is unfit for use.
- The harness is intact, the stitches are not torn, there are no cuts in the belts, the attachment rings are in order and their threads are intact.
- It must be checked that the fall arrester locks on the vertical rail.
- The labels of the fall arrester and the rail system must be legible.

A damaged fall arrester must be repaired by the manufacturer or its authorised representative. A damaged fall arrester or rail system may not be used.

NOTE! REGULAR INSPECTIONS ENSURE THE SAFETY AND COMFORT OF THE RAIL SYSTEM USER

Periodic inspections

The overall condition and operation of the vertical rail system must be inspected every 12 months after the system has been taken into use. The inspection is conducted by the property owner or the person in charge of safety in the property. The inspection is recorded in the data card provided with the fall arrester. The inspection must cover the following:

Fall arrester:

- Condition of the springs of the fall arrester: the springs must be in place, and they may not be broken or lost their elasticity.
- The energy absorbers (2/fall arrester) are in order and have not deployed due to a fall. If orange colour and text is visible underneath the cover, the energy absorber is unfit for use. The maximum allowable energy absorber length is 160 mm (between the O ring and the D ring).
- The harness is intact, the stitches are not torn, there are no cuts in the belts, the attachment rings are in order and their threads are intact.

- It must be checked that the fall arrester locks on the vertical rail.
- The labels of the fall arrester must be legible.

A damaged fall arrester must be repaired by the manufacturer or its authorised representative. A damaged fall arrester may not be used.

Vertical rail:

- The screws of the rung fixtures and extension parts must be tight.
- The fall arrester's stoppers, if any, must be in place.
- No mechanical damage or damage due to corrosion is visible in the vertical rail system.
- The labels of the vertical rail system must be legible.

Any defective and damaged parts must be repaired or replaced before use.

Harness:

- The harness must be inspected according to the manufacturer's instructions. A test climb must be conducted to inspect the operation of the fall arrester.

NOTE! REGULAR INSPECTIONS ENSURE THE SAFETY AND COMFORT OF THE RAIL SYSTEM USER

8. Servicing and maintenance

The rail system and its parts do not require any specific maintenance. The system is inspected for damage in the periodic inspections, and the required repair actions are determined. The expected lifetime of the products is 15 years for the galvanised parts of the rail system and 30 years for the powder-coated parts. The lifetime depends on the care given and the location of the building (urban atmosphere vs countryside). The expected lifetime of the fall arrester is 15 years, depending on the care. The estimated average lifetime of the flexible energy absorber (textile parts) is 5 years and a maximum of 10 years. The product's lifetime may be reduced by the following: poor storage, poor use, arresting of a fall, mechanical damage, contact with chemicals (such as acids and bases), exposure to heat (> 60°C).

9. Package

The fall arrester + flexible energy absorber combination is packed in a moisture-resistant plastic bag (energy absorber). Instructions for use are included. If the product is resold outside Finland, the instructions for use, maintenance instructions and the instructions for periodic instructions must be provided in the language of the country of destination.

10. Labels

The fall arrester + flexible energy absorber has the following labels:

Fall arrester:

Manufacturing batch and year (such as 09 08)

Flexible energy absorber:

Manufacturer

Product name

Manufacturer's contact information

ID of the notified body participating in quality control (0598)

European standard used for assessment (EN 353-1:2014 + A1:2017)

An icon telling the user to read the instructions for use:



Serial number of the flexible energy absorber

11. Approvals

The vertical rail and the fall arrester + energy absorber have been tested and approved in accordance with the requirements of EN 353-1:2014. Type issue certificate No. 16513PRS01 has been issued for the vertical rail system by the Fimko Ltd (notified body No. 0598), and the product is monitored by it.

Notified body No. 0598

SGS Fimko Ltd, Takomotie 8

00380 Helsinki

Vesivek Tuotteet Oy Teollisuustie 8 FI-16300 ORIMATTILA 16
EN 353-1:2014 + A1:2017 Putoamissuojaimet osa 1: Kiinteässä johteessa liikkuvat liukutarraimet DoP: vesivek.fi

INSPECTION CARD FOR FALL ARRESTER AND RAIL SYSTEM

Manufacturer: **Vesivek Tuotteet Oy, Teollisuustie 8, FI-16300 Orimattila**
 Retailer:
 Serial numbers: Fall arrester: Absorbers:
 Year of manufacture:

The fall arrester can only be used in Vesivek Tuotteet Oy vertical rails in combination with an CE approved (EN-361) full-body harness. The arrester attaches to the front attachment point/points of the harness. Both flexible energy absorbers of the fall arrester are attached and secured to the front attachment point/points using their eyebolts.

Inspect the operation of the fall arrester and the condition of the harness according to the manufacturer's instructions before each use. Furthermore, the personal protective equipment and the rail systems are subject to an annual periodic inspection according to the manufacturer's instructions.

Purchase date: _____ / _____ 20____
 Taken into use: _____ / _____ 20____
 User: _____

INITIAL INSPECTION AND PERIODIC INSPECTIONS

Inspection date	Inspector	Actions	Following inspection

Store this card with the fall arrester with flexible energy absorber!