

Snow guard for roofs with load-bearing profiles

1. Planning the location

- The snow guard is placed where snow falling from the roof forms a hazard or some other reason exists for preventing the snow from falling.
- The snow guard should always be installed over the entire length of the eaves. It should not be used as short sections over the entrances only, for example.
- Snow must always be prevented from falling from one roof plane to another as well.
- Place the snow guard close to the side eaves so that the snow loads are transferred to the load-bearing structures.

2. Dimensioning of snow guards and fixture types

Maximum roof plane length above the snow guard (m)						
Angle (°) and slope ratio of the roof	Distance between snow guard fixtures (m)					
Snow load on the roof 1.8 kN/m ² (2.6 kN/m ²)						
	0.5 m	0.6 m	0.75 m	0.9 m	1.0 m	1.2 m
< 15°, (1:3.7)	21.4 (15.0)	17.9 (12.5)	14.3 (9.9)	12.0 (8.3)	10.7 (7.4)	9.0 (6.2)
15...22°, 1:3.7...1:2.5	11.4 (8.0)	9.5 (6.6)	7.6 (5.3)	6.3 (4.4)	5.7 (4.0)	4.8 (3.3)
22...27°, 1:2.5...1:2	8.4 (5.8)	7.0 (4.8)	5.6 (3.9)	4.7 (3.3)	4.2 (2.9)	3.5 (2.4)
27...37°, 1:2...1:1.3	7.4 (5.2)	6.2 (4.3)	4.9 (3.4)	4.1 (2.8)	3.7 (2.6)	3.1 (2.1)
37...45°, 1:1.3...1:1	9.0 (6.2)	7.5 (5.2)	5.9 (4.1)	5.0 (3.5)	4.5 (3.1)	3.7 (2.6)

Fixture types for different profiles

Roofing types	New roofing types	Fixture type
Rannila 45J A, B, R	Ruukki T45	KL3 RAN45-70 ks/le side fixture (angle approximately 124°)
Rannila 45 A, B, R		"
Plannja Hovi 45		"
Weckman W-45JR, W-45JA		"
Rannila 45 EA, EB		KL3 RAN45-70E ks/le side fixture (angle approximately 133°)
Plannja Hovi 45 ER, EV		"
Weckman W-45E, W-45ER		"
Plannja 70		KL3 RAN45-70E ks/le side fixture (angle approximately 108°)
Rannila 70	Ruukki T70	KL3 RAN45-70 ks/le side fixture (angle approximately 124°)
Weckman W-70		"
Rannila 113 and 120	Ruukki T130	KL3 RAN113-120 ks/le side fixture (approximately 115°)
Plannja 111 and 111M		"
Weckman W-115, W-130		"
Rannila 153	Ruukki T153	KL3 RAN153 ks/le side fixture (approximately 111°)
Weckman W-155		"

- Snow guards and fixtures are dimensioned to sustain a load of 5 kN/metre.
- The lowest snow guard tube is fixed near the profile ridges using the side fixtures. Snow floes can, however, slide under the snow guard in the grooves. In order to guarantee the operation of the snow guards, we recommend installing groove stops for over 70 mm profiles.

3. Parts of snow guards

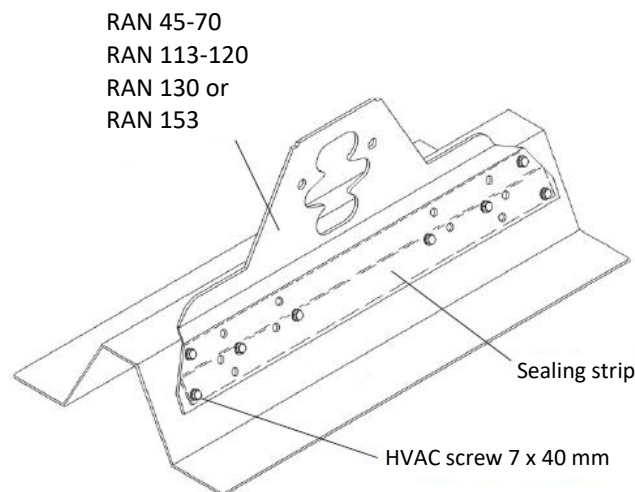

4. Installation order

1. Plan the placement.
2. Calculate the fixture distance according to the recommendation of the snow guard table.
3. Mark the locations of the snow guards (using a chalk line, for example) and make sure that the fixtures are in line.
4. Glue the sealing strip on the fixtures where the screws will be placed to prevent any leaks. If necessary, use sealant strip in two rows. Attach with 7 x 40 mm HVAC screws.

The number of screws is selected according to the profile material thickness:

Profile thickness mm	screws/fixture, pcs.
0.6	8
0.7–0.8	6
over 0.8	5

5. Place the snow guard tubes/Pyry profile in their places. NOTE! Install the Pyry profile so that the top of the “A” faces the ridge. The tubes/profile closest to the ends may exceed the last fixture by maximum 100 mm.
6. Snow guard tubes can be extended by pushing the tapered end into the other tube and locking the connection with an M8 x 30 mm hexagonal screw and an M8 nut. Sideways movement is prevented by placing M8 x 30 mm hexagonal screws and M8 nuts at the ends.

Snow guard profile Pyry can be extended by overlapping the profiles by over a distance of minimum 85 mm and locking the connection with four self-drilling screws. Sideways movement is prevented by placing 6.3 x 19 mm self-drilling screws at the ends.