

Snow guard for tile roof

1. Planning the location

- Entrances and accessways as well as play and recreational areas used during the winter must be protected from snow and ice falling from the roof. This regulation also applies to the streets and other public areas surrounding the building.
- When the slope of the roof is steeper than 1:8, snow guards are used for protection.
- The snow guard should always be installed over the entire length of the eaves. It should not be used as short sections over the entrances only, for example.
- Snow must always be prevented from falling from one roof plane to another as well (RT instruction card 85-10708).
- Place the snow guard close to the side eaves so that the snow loads are transferred to the load-bearing structures.

2. Dimensioning of snow guards

Maximum roof plane length above the snow guard (m)						
Angle (°) and slope ratio of the roof	Distance between snow guard fixtures (m)					
Snow load on the roof 1.8 kN/m ² (2.6 kN/m ²)						
	0.5 m	0.6 m	0.75 m	0.9 m	1.0 m	1.2 m
< 15°, (1:3.7)	21.4 (15.0)	17.9 (12.5)	14.3 (9.9)	12.0 (8.3)	10.7 (7.4)	9.0 (6.2)
15...22°, 1:3.7...1:2.5	11.4 (8.0)	9.5 (6.6)	7.6 (5.3)	6.3 (4.4)	5.7 (4.0)	4.8 (3.3)
22...27°, 1:2.5...1:2	8.4 (5.8)	7.0 (4.8)	5.6 (3.9)	4.7 (3.3)	4.2 (2.9)	3.5 (2.4)
27...37°, 1:2...1:1.3	7.4 (5.2)	6.2 (4.3)	4.9 (3.4)	4.1 (2.8)	3.7 (2.6)	3.1 (2.1)
37...45°, 1:1.3...1:1	9.0 (6.2)	7.5 (5.2)	5.9 (4.1)	5.0 (3.5)	4.5 (3.1)	3.7 (2.6)

If this load is exceeded, the snow load on the roof must be reduced.

NOTE! The maximum allowed distance between the fixtures of a snow guard grid is 1,050 mm.

3. Snow guard options

1-tube	1 oval tube length 300 cm	effective length 294 cm
2-tube	2 oval tubes length 300 cm	effective length 294 cm
Profile	1 LP3 profile length 300 cm	effective length 291.5 cm
Grid-type snow guard	1 grid-type snow guard length 300 cm	effective length 291.5 cm

In the 1-tube snow guard, the fixture is TKLO1

In the 2-tube and Pyy profile snow guards, the fixture is TKL3

In the Varma grid-type snow guard, the fixture is TKLO1 + RLE-YK

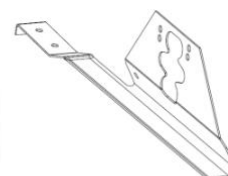
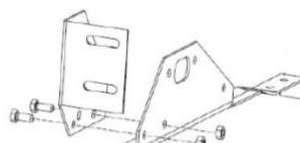
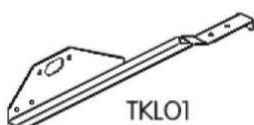

4. Installation order

A temporary support is always used for attaching the snow guard on tile roof. Minimum dimensions of the wooden temporary support are 50 x 100 mm, class T24.

1. Plan the placement.
2. Determine the distance between fixtures according to the recommendations of the dimensioning tables.
3. Fix the temporary supports as shown in the figure so that the top edge of the support is approximately 150 mm from the top edge of the tile roof's roof batten.

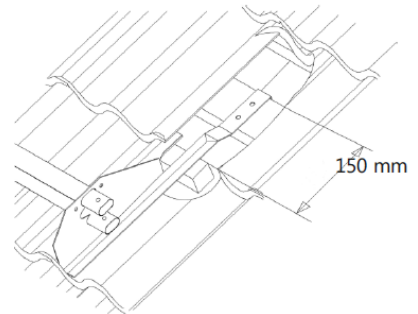

4. Use minimum two 6 x 120 mm screws or 6" hot-dip galvanised nails to attach the temporary support through the spacer lath to the roof truss. Place screws to every roof truss so that one of the screws is at an angle as shown in the figure. The screws must be placed at minimum 15 mm from the edge of the temporary support.

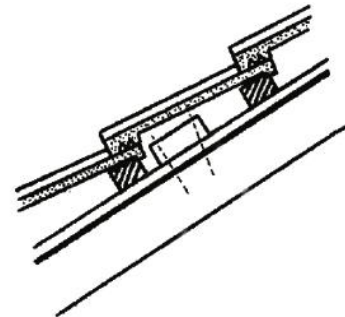

5. At the end of the snow guard, the temporary support must extend until the next roof truss. The temporary supports can be extended by joining them at the roof truss, fixing both ends to the roof truss as described above.

6. Attach the snow guard fixtures to the temporary support with two 7 x 50 mm HVAC screws.

7. NOTE! This section only applies to AAVA slates. When using AAVA slates, plastic spacer rings KT2 must be placed between the fixture and the temporary support as shown in the figure. In the case of AAVA tiles, the correct fixture location is approximately 75 mm from the edge of the tile so that the fixture is not placed to the seam between the tiles.

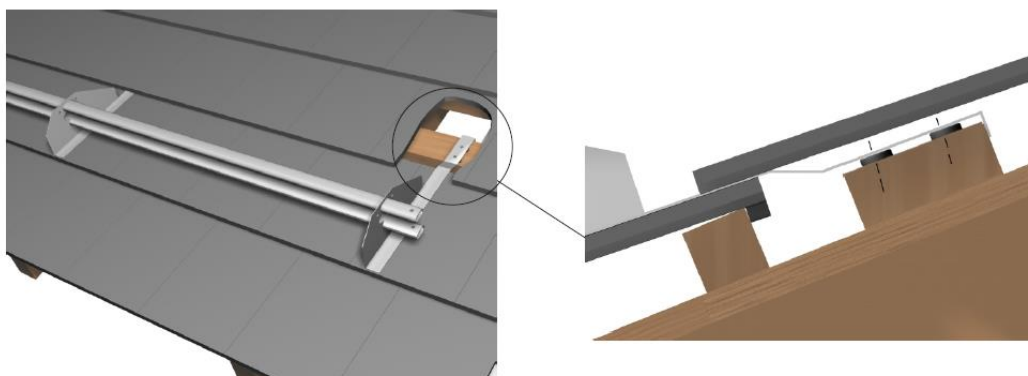
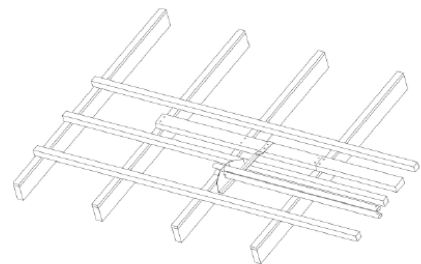

8. If necessary, use a diamond disc to cut a piece off the tile at the location of the fixture to ensure that the tile sits firmly in its place.

9. Place the snow guard tube/tubes/profile/grid in its place. The tubes/profiles/grids closest to the ends may exceed the last fixture by maximum 100 mm. In the profile, point A faces the ridge, and in the grid, points U. Use two M8 x 20 mm hexagonal screws, two Varma washers and two M8 nuts to attach the grid to the RLE-YK fixture frame. Place washer between the oval holes in the top fixture and the nut/bolt head and between the grid and the nut/bolt head.



10. Snow guard tubes can be extended by pushing the tapered end into the other tube and locking the connection with a 8 x 30 mm hexagonal screw and an M8 nut. Sideways movement is prevented by placing M8 x 30 mm hexagonal screws at the ends.

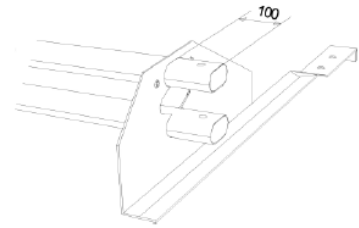

Snow guard profile Pyry can be extended by overlapping the profiles by over a distance of 80 mm and locking the connection with two M8 x 30 mm hexagonal screws and M8 nuts. Sideways movement is prevented by placing 6,3 x 19 mm self-drilling screws at the ends.

The grid-type snow guard can be extended by overlapping the grids over a distance of minimum 85 mm and locking the connection with two M8 x 20 mm screws and M8 nuts.

