

## Roof treads for standing seam roof

### 1. Planning the location

- Roof treads are designed and manufactured according to EN 12951, class 2. When installed according to these instructions, roof treads can be used as a safety line anchor point (= class 2).
- The safety line must be attached around a tread. The line may not be attached to the fasteners.
- The safety line may only be used on the same roof plane as the treads, in the direction of the eaves, and the line must be dimensioned in such a way that the user cannot fall over the eaves.
- An approved safety line (EN 353-2) with fall arrest system and length adjustment must be used. Retractable type fall arresters (EN 360) may be used instead of safety line.
- A roof tread may only be used as safety line anchor point by one person at a time. The maximum weight of the person using the anchor point, including equipment, is 100 kg.

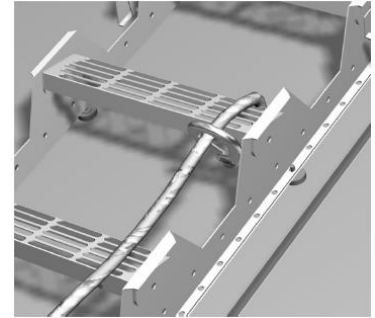

### 2. Planning

- Safe access must be provided for all items on the roof that need maintenance. Roof treads are used for access between the eaves and the ridge on low pitch roofs (slope 1:3 or gentler).
- Access to the roof can be arranged from the side or the end of the building. We recommend arranging access to the roof through wall ladders from the end of the building and continuing the access route without interruption as a roof walkway. A prerequisite for this is that the wall ladder and the roof walkway can be placed at the same location. Wall ladders installed on the side of the building are always sensitive to snow loads if the building is not fitted with snow guards.
- Nesco's vertical safety rail can only be installed on class 2 roof ladders.
- The roof structures must fulfil the instructions of RT instruction card 85-10862.
- The minimum roof size for installation in accordance with class 2 is 2 m x 2 m.

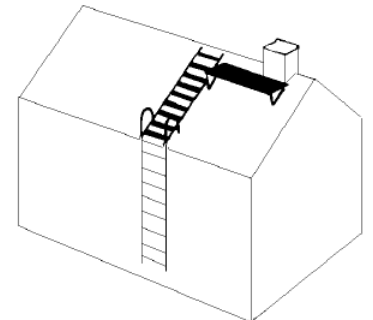

### 3. Dimensions and dimensioning of roof treads

- The tread element length is 2.84 m. Consecutive elements overlap 0.14 m, i.e. the effective length is 2.7 m.
- The free width between the side rails is 380 mm.
- The tread distance is 300 mm and the slope is 1:3 (18.3°).
- The products are designed to sustain a point load of 1.5 kN (approximately 150 kg).

## 4. Parts of the roof treads

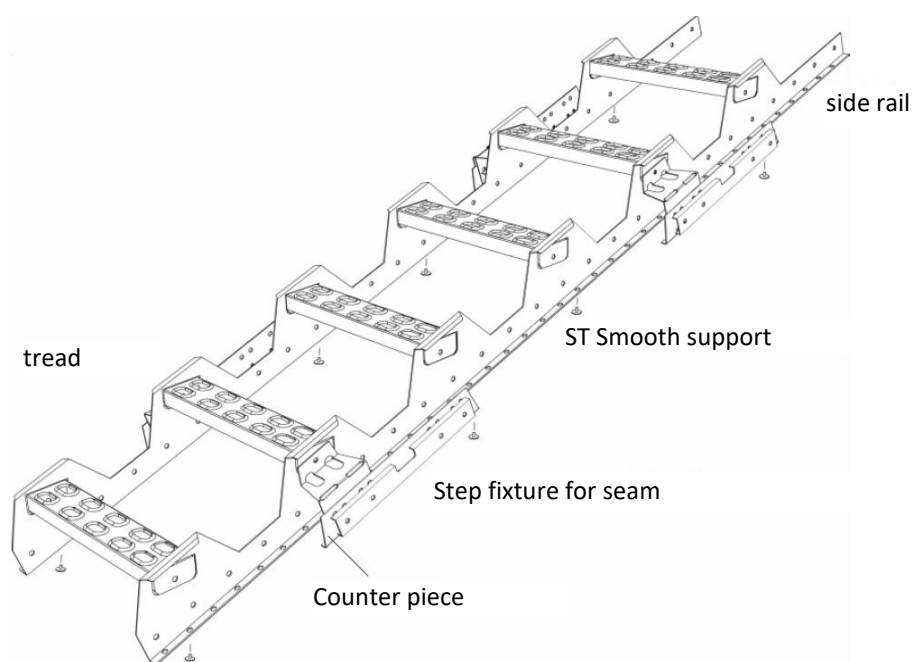

## 5. Installation order

1. Plan the placement.
2. Measure the distance from the eaves to the ridge and deduct 0.3 m to determine the required tread length. Note! The treads do not always run from the ridge to the eaves. They can also run to roof walkway or roof hatch, for example.
3. Assemble the roof treads by pushing the treads into the pockets on the sides of the side rails. Use M8 x 20 mm (16 mm) screws and M8 mm nuts to lock the connections. Place the step fixtures for seam under the screw on both sides as at intervals specified in the table below. Note that the fixture consists of three parts. The counter piece is always placed on the side where the seam is bent down.

Number of step fixtures for seam			
Roof plane length, m	up	down	in between
0–4	2	2	0
4–6	2	2	2
6–8	2	2	4

4. Place the smooth supports of the treads at approximately 0.7–0.8 m intervals. Push the smooth supports into the holes at the bottom of the rail's side. The supports serve to soften the contact surface between the treads and the roofing.
5. Lift the pre-assembled elements on the roof and tighten the screw of the step fixture for seam.
6. Attach the next element(s) to the element at the top. Use M8 x 20 mm (16 mm) bolts and M8 nuts to lock the connections. The treads can be extended by overlapping the elements by 140 mm.
7. The bottom of the treads can be attached to the top curve of the wall ladder.

## 6. Maintenance

- In order to keep the installation as a class 2 system, the installation must be inspected once a year by an inspector authorised by the manufacturer.
- The roof treads are not dimensioned to sustain the snow load of the entire roof and especially not moving masses of snow. Snow must, therefore, be prevented from moving and the stress must be directed at the snow guards. If no snow guards have been installed, snow must be cut regularly on both sides of the roof treads to reduce loads.

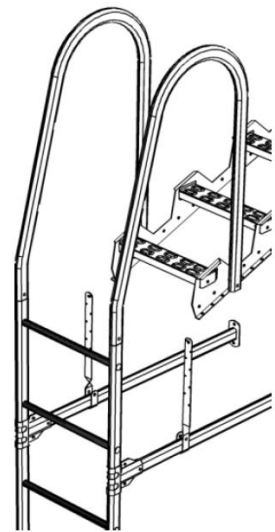

CE

Vesivek Tuotteet Oy

Teollisuustie 8  
FI-16300 ORIMATTILA

13  
EN 12951

Kiinteästi asennetut kattotikkaat  
C2-TA

DoP: vesivek.fi