

Roof ladder for standing seam roof

1. Instructions for use

- Roof ladders are designed and manufactured according to EN 12951, class 2. When installed according to these instructions, the roof ladder can be used as a safety line anchor point (= class 2).
- We recommend attaching the safety line around the side rails, but it can also be attached to the rungs (figure 1).
- NOTE! The safety line may not be attached to the fixtures or the plastic feet.
- The safety line may only be used on the same roof plane as the ladder, in the direction of the eaves, and the line must be dimensioned in such a way that the user cannot fall over the eaves.
- An approved safety line (EN 353-2) with fall arrest system and length adjustment must be used. Retractable type fall arresters (EN 360) may be used instead of safety line.
- A roof ladder may only be used as safety line anchor point by one person at a time. The maximum weight of the person using the anchor point, including equipment, is 100 kg.



2. Planning

- Safe access must be provided for all items on the roof that need regular maintenance or inspections if the slope of the roof is steeper than 1:8 (7°).
- Using a separate snow guard at the roof ladder location is recommended. The roof ladder is not a snow guard.
- Plan the placement of the roof ladder and the wall ladder so that they are at the same place.
- Vesivek vertical safety rail can only be installed on class 2 roof ladders.
- The roof structures must fulfil the instructions of the manufacturer.
- The minimum roof size for installation in accordance with class 2 is 2 m x 2 m.

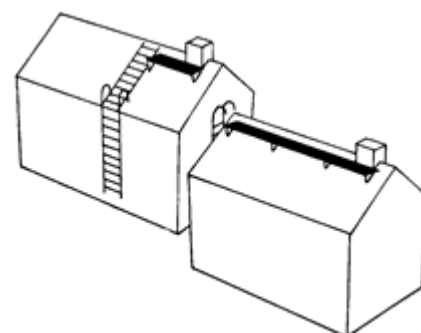

3. Dimensioning of roof ladders

- The free distance between the side rails of roof ladders is 400 mm.
- The step distance of the ladder is 300 mm.
- If the roof ladder extends until the ridge, the suitable length of the roof ladder equals the roof plane length minus 20 cm.
- The products are designed to sustain a point load of 1.5 kN (approximately 150 kg).

4. Parts of the roof ladder

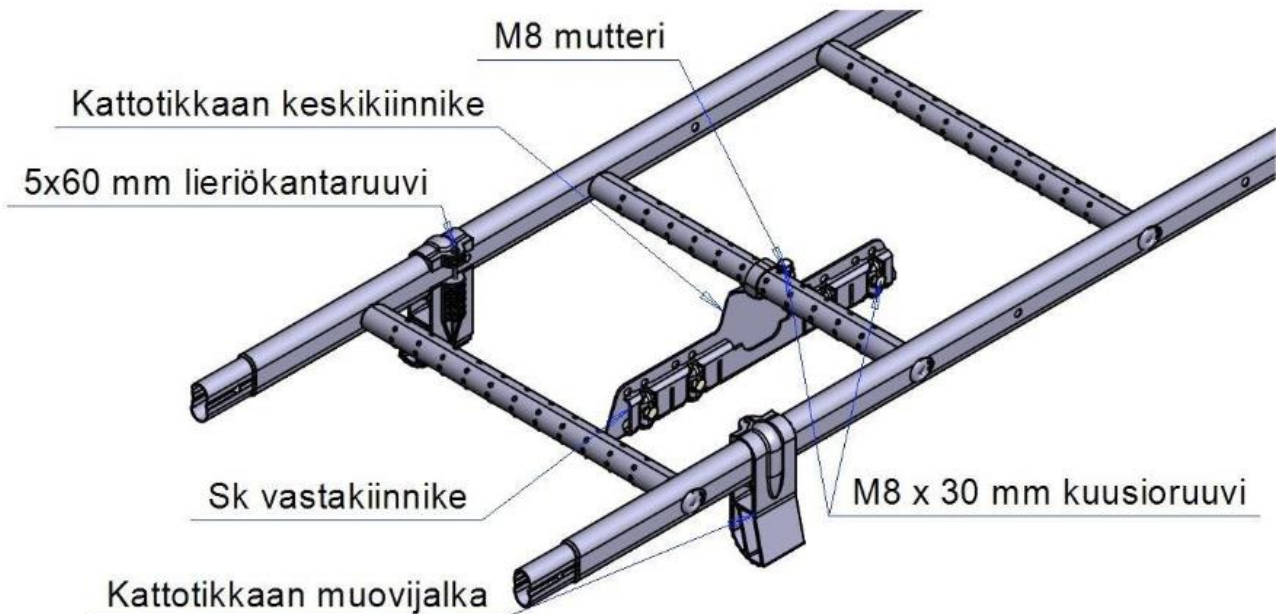

5. Installation order

1. Measure the required ladder length. If necessary, cut the ladder with a hacksaw or extend with another ladder. One end of the ladder is narrower than the other so that the sections overlap when placed in a row. Use M8 x 40 mm bolts to lock the connections. If the ladder length is over 6 m, the sections should only be connected to the roof after the top section has been attached on the roof.
2. Place the plastic feet provisionally in the ladder side rails already on the ground. Place the feet at 1.5 m intervals. The feet can be rotated around the side rail. Place the tightening screws (5 x 60 mm) of the feet in their places but do not tighten them yet.

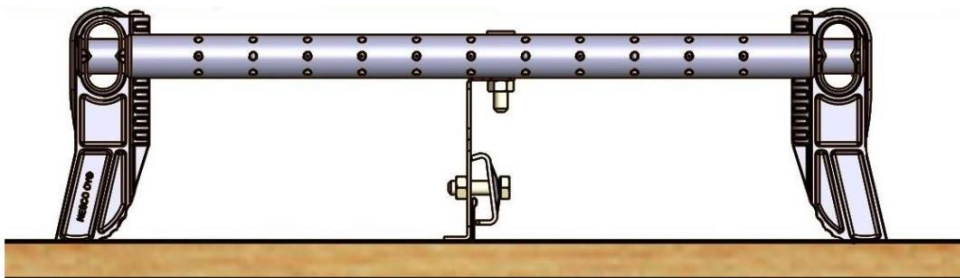

3. Assemble the centre fixtures of the roof ladder for standing seam roof by attaching the SK seam fixture with four M8 x 30 mm screws and M8 nuts. Do not tighten the screws.
4. Always install at least 2 fixtures, one at the top of the ladder and one at the bottom. If the ladder length is over 6 m, install fixtures every 3 metres.

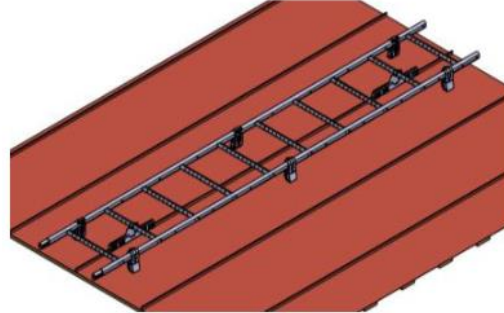
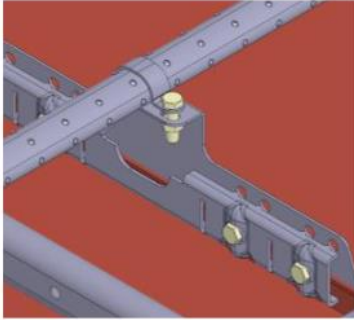

5. Attach the preassembled centre fixtures in the middle of the ladder's rungs. To do this, pass the fixture handles around the ladder's rungs and tighten them in place with an M8 x 30 mm hexagonal screw and an M8 nut. Always attach the foot to the ladder so that the "straight section" of the roof's seam is against the actual foot.
6. Lift the ladder to the correct place on the roof.
7. Tighten the screws of the counter piece. Ensure that the seam of the roof, approximately 25 mm high, is pressed between the centre fixture and the fixtures on the seams. The tightness is correct when the counter piece begins to bend a bit.
8. Tighten the cylinder head screws of the plastic feet.
9. The bottom of the ladder is often attached to the top curves of the wall ladder as well. Attach with two U-flanges, an M8 x 40 mm hexagonal screw and an M8 nut.

6. Maintenance

- Inspect the tightness of the roof ladder fixture screws every 4 months during the first year. After this, inspect once a year. In order to keep the installation as a class 2 system, the installation must be inspected once a year by an inspector authorised by the manufacturer.
- The roof ladder is not dimensioned to sustain the snow load of the entire roof and especially not moving masses of snow. Snow must therefore be prevented from moving and the stress must be directed at the snow guards. If no snow guards have been installed, the snow must be cut regularly on both sides of the roof ladder to reduce loads.

CE

Vesivek Tuotteet Oy

Teollisuustie 8
FI-16300 ORIMATTILA

13

EN 12951

Kiinteästi asennetut kattotikkaat
C2-TB

DoP: vesivek.fi